

# Bal Spring<sup>®</sup> Canted Coil Spring

Solutions for EMI/RFI Shielding Applications

Custom components that drive tomorrow's technologies.<sup>®</sup>

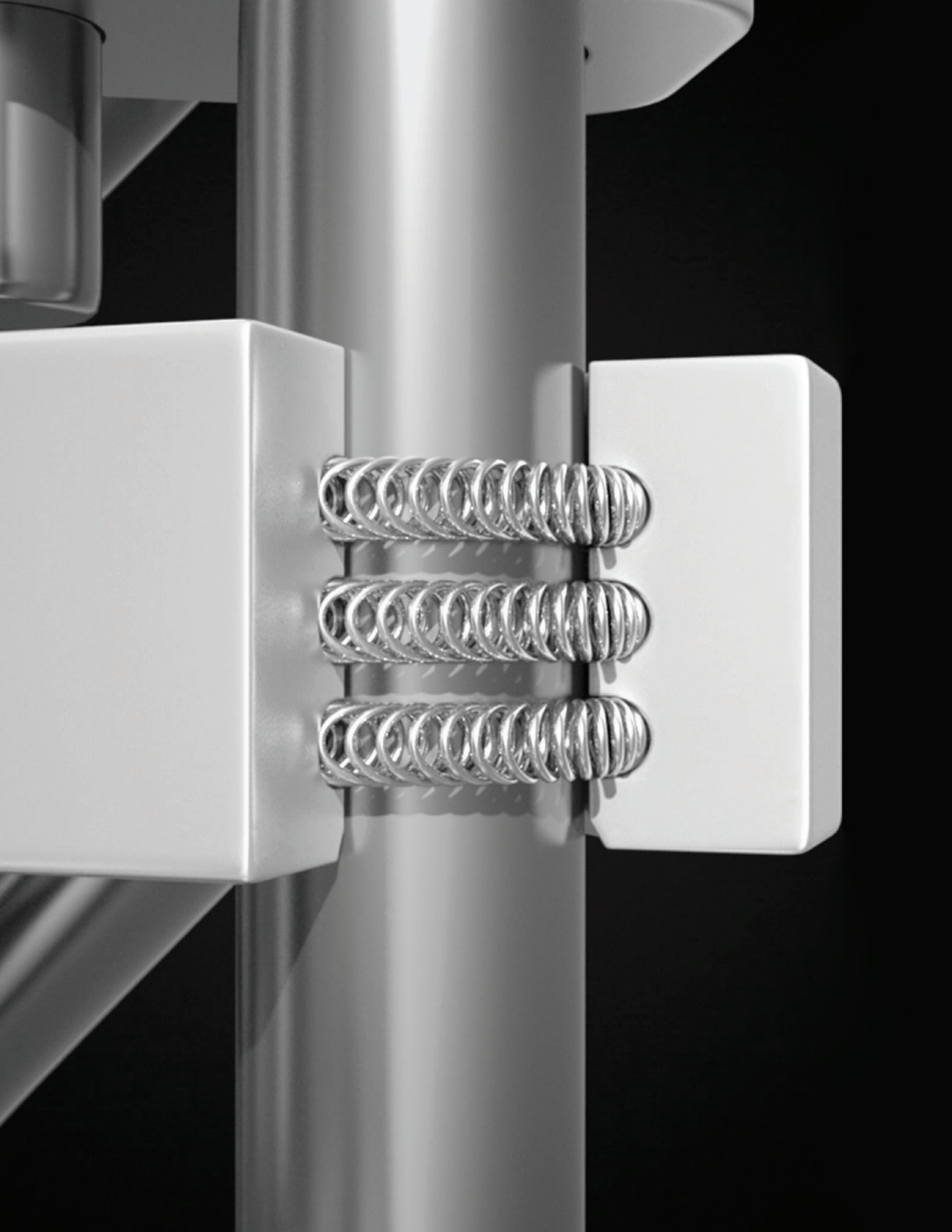



## Contents

- 2** Product Innovation Through Engineering Collaboration
- 3** Shielding with Springs
- 4** Benefits of Bal Spring® Canted Coil Spring Design
- 5** Effective EMI/RFI Shielding
- 6** Applications
- 8** EMI Shielding Test Data
- 10** Materials & Plating
- 12** Important Information



# Product Innovation Through Engineering Collaboration

At Bal Seal Engineering, we create custom electromagnetic interference/ radio-frequency interference (EMI/RFI) shielding solutions that improve the performance and reliability of the equipment you design and manufacture.

For more than 65 years, we've helped some of the biggest names in worldwide industry gain a competitive edge. And in many cases, we've helped to develop breakthroughs and shape industry standards along the way. Our collaborative engineering approach enables us to forge "innovation partnerships" with engineers like you who want to make their products stronger, faster, lighter, or more functional.

In early development or existing product improvement stages, we combine our proven core products with application engineering, precision manufacturing and material science expertise to produce solutions that deliver.



## The Bal Spring®: A Proven Performer

The Bal Spring canted coil spring is a versatile component that shields sensitive electronics from the harmful effects of EMI/RFI. The spring's independent coils, which serve as multiple contact points for optimal conductivity and/or grounding performance in shielding applications, ensure consistent, reliable connection—even under shock and vibration.

The Bal Spring's highly conductive properties and unique design enable it to provide superior shielding, particularly in high-frequency, small-package applications. It can also be used to mechanically fasten with precisely controllable insertion and removal forces, thereby reducing system complexity and weight.



## Shielding with Springs

Global demand for shielding solutions to address electromagnetic and radio-frequency interference is on the rise due to the need to prevent equipment failure in aerospace, defense, automotive, telecommunications, and many other industries. Shielding from EMI and RFI is vital to preventing damage to critical systems and components.

Bal Spring® canted coil springs have been tested and proven to provide effective shielding in the packaging of electronic enclosures. They also offer additional benefits afforded by their design, including outstanding durability and reliability.

The Bal Spring canted coil spring is available in a variety of sizes and configurations:

- Cross sections range from a coil height (CH) of 0.016 to 0.500 in. (0,41 to 12,70 mm)
- Ring diameters range from 0.020 in. (0,508 mm)
- Base materials include various copper alloys and stainless steel alloys
- Variety of platings available, including gold, silver, nickel, and tin
- Forms include precision cut lengths and closed/welded rings

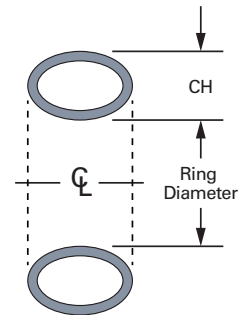

### Typical Spring Groove Configurations

The following groove configurations, which are the result of extensive design and independent laboratory testing, have been proven to optimize the shielding performance of our Bal Spring canted coil springs. These configurations are readily adaptable to many hardware applications.

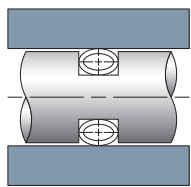

Flat Piston

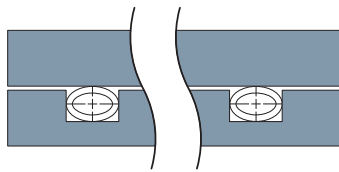

Flat Plate

**Rectangular**  
Easiest to machine

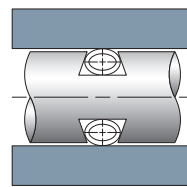

Dovetail Piston

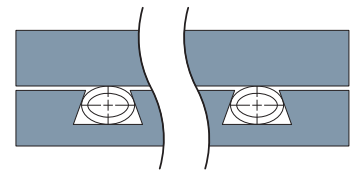

Dovetail Plate

**Dovetail**  
Best for retaining spring in place

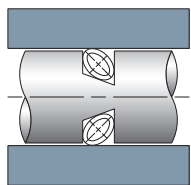

Tapered Piston

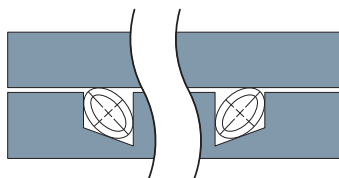

Tapered Plate

**Tapered Bottom**  
Best control of forces

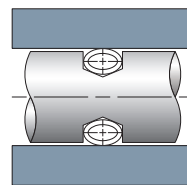

V Piston

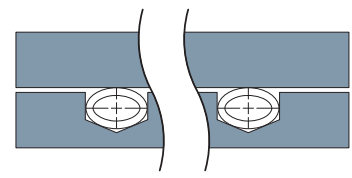

V Plate

**V Groove**  
Best conductivity

See page 6 for axial and radial load assembly applications.



# Benefits of Bal Spring® Canted Coil Spring Design

Bal Spring canted coil springs exhibit a unique deflection and force behavior upon compression. The springs are available as closed rings or straight lengths, in a variety of sizes and materials to meet demanding shielding requirements.

The spring offers long-term durability because of its high resistance to compression set provided by spring resilience. Conductivity across the interface is preserved by highly concentrated forces at multiple contact points. Due to its near constant force over a large compression range, the spring provides consistent shielding despite surface irregularities and tolerance variations (see Figure 1). It is available in very small ring diameters and cross sections, with various groove options, and the spring is self-retained in grooves with no adhesives required. Low compression forces from light spring loads ensure easy assembly. The multi-function spring provides mechanical latching and locking in addition to electrical conducting and EMI/RFI shielding.

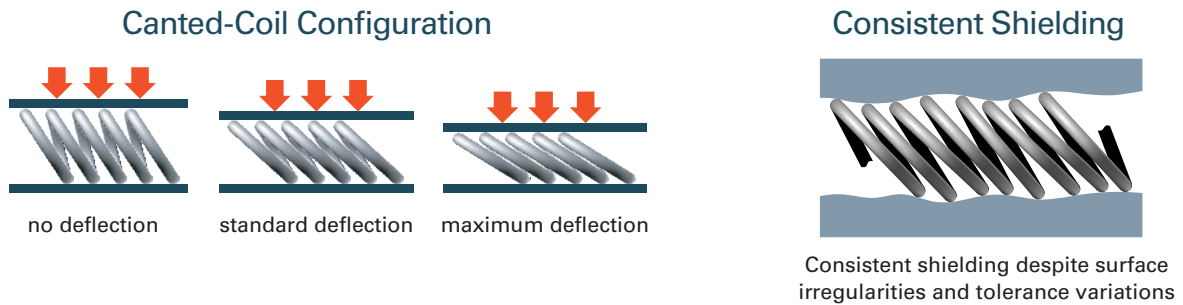

## Spring Force and Deflection

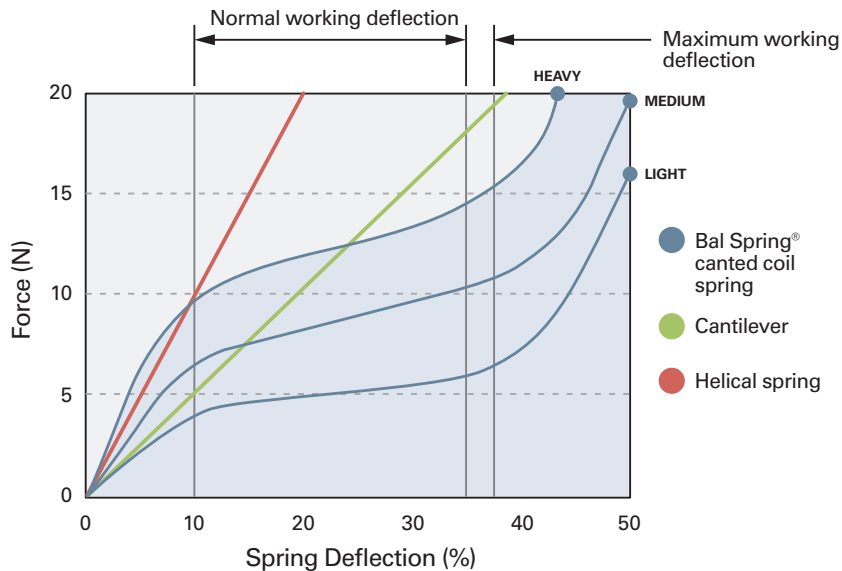

**Figure 1.** Unlike typical spring technologies, the Bal Spring® canted coil spring provides nearly constant force across the working deflection.

## Effective EMI/RFI Shielding

The Bal Spring's highly conductive properties and unique design enable it to provide superior shielding against EMI/RFI, particularly in high-frequency, small-package applications. As an interface shielding component, the spring offers designers a simple, economical means to greatly reduce radiated emissions and conducted interference.

**Figure 2** at right indicates the superior shielding effectiveness of the Bal Spring canted coil spring compared with other shielding options. Summary test data shows that the spring exhibits much lower transfer impedance than finger stock, helical flat springs, or wire mesh over elastomer.

**Figures 3 and 4** at right illustrate the Bal Spring's shielding effectiveness at frequency ranges of 1–10 GHz and 100 MHz–1 GHz. Tests were conducted on a 50-Ω characteristic impedance coaxial connector using a copper alloy Bal Spring with silver plating as a shielding element. The spring was shown to provide up to 90 db of attenuation.

Compared with no spring, stainless steel shows greatly improved shielding effectiveness, which may be sufficient for some applications. BeCu, which shows even greater shielding effectiveness, is recommended for high-performance shielding requirements.

*Note: shielding effectiveness is highly dependent on connector design and configuration.*

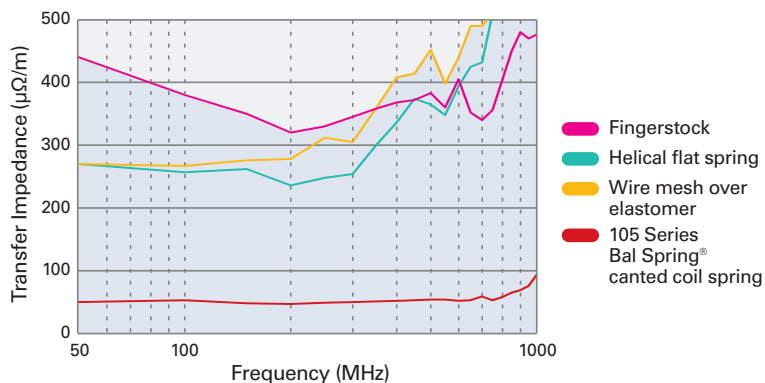

**Figure 2.** Transfer impedance of canted coil spring vs. other shielding methods.

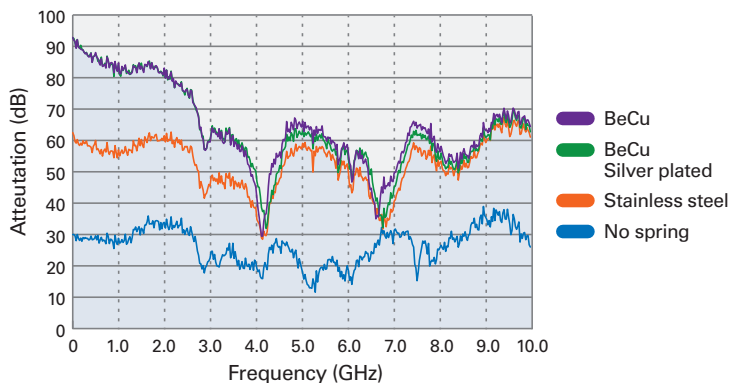

**Figure 3.** 100 MHz–1 GHz, attenuation vs. frequency.

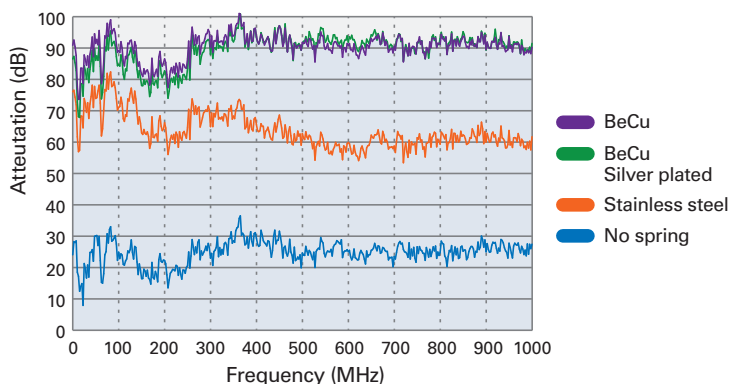

**Figure 4.** 1–10 GHz, attenuation vs. frequency.



# Applications

The versatile design of Bal Spring<sup>®</sup> canted coil springs allows them to be employed in a variety of applications. The set of typical groove configurations on page 2 optimizes spring performance in various user geometries. The most common assembly orientations are shown below along with a typical example.

## Axial Load Assembly

For applications involving flat, planar interfaces: The groove may be a linear or closed shape, while the spring may be a free length or ring. The spring is retained in the groove with a light preload during installation and assembly. The mating surface compresses and captivates the spring when assembled. See Figure 5.

**Figure 5**  
Typical Axial Application Electronic Enclosure

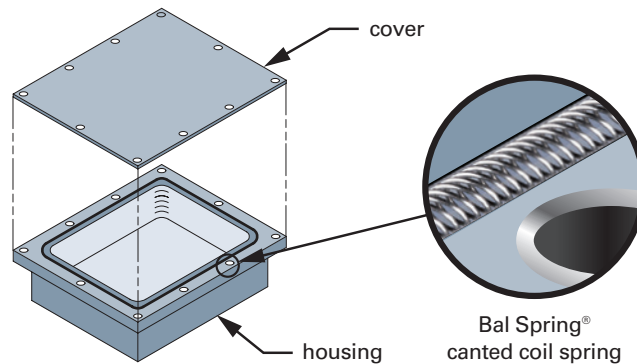

## Radial Load Assembly

For plug and socket arrangements: The spring in a closed ring form is mounted in the groove on the plug. Coil tension retains the part in the groove through installation. The mating housing compresses and captivates the spring as assembled. See Figure 6.

**Figure 6**  
Typical Radial Application Electrical Connector

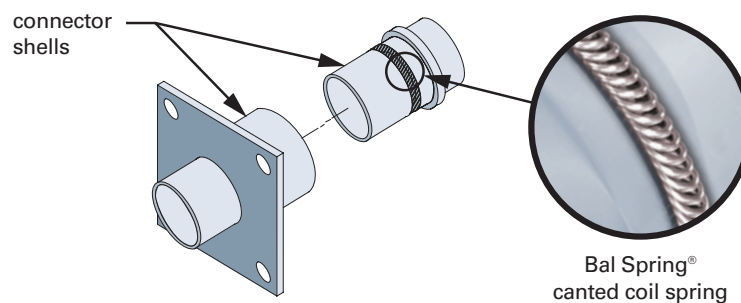



### Connect/Disconnect Assembly

For applications requiring strong retention or locking between plug and socket parts: The spring is mounted in the groove on the plug. Groove designs on both parts are available for different mating conditions, loading levels, and load sensitive release mechanisms. The mating housing compresses and captivates the spring as assembled. See Figure 7.

**Figure 7**  
Typical Connect/Disconnect Assembly

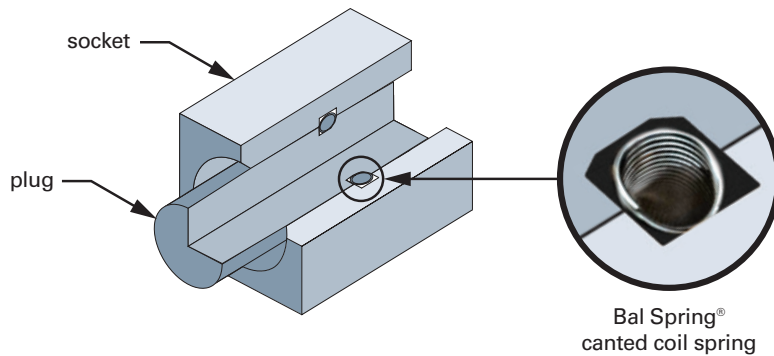

### Other Sample Applications

The spring can be used in a combination of different arrangements. The groove does not have to be rectangular or round; It can follow the shape of the cavity. The interface can be pure axial, radial, or a combination of both. See Figures 8 and 9.

**Figure 8**  
Coaxial Connector

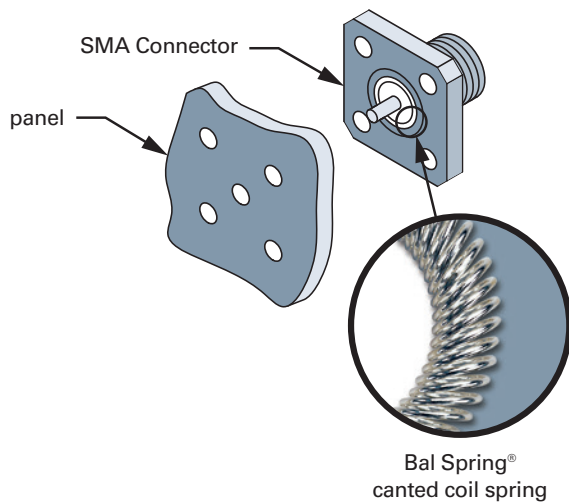

**Figure 9**  
Waveguide Flanges

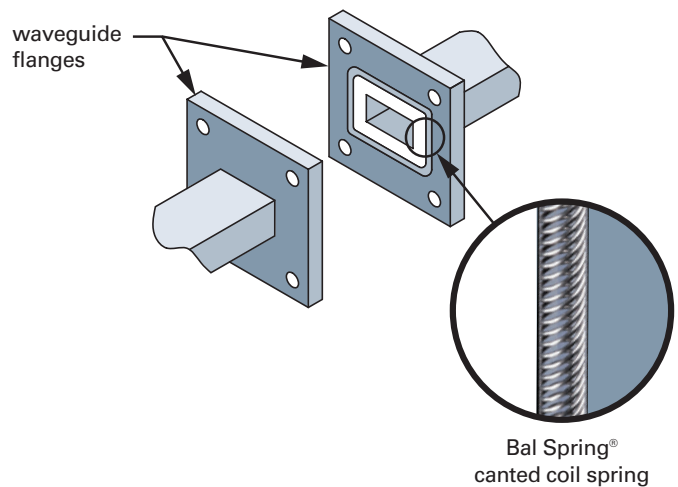



# EMI Shielding Test Data

We maintain a library of data of transfer impedance ( $Z_T$ ) and shielding effectiveness (SE) measurements for springs. This data is the product of extensive testing to the standards of MIL-G-83528 for shielding effectiveness and SAE ARP 1705 for Transfer Impedance, conducted by an independent test laboratory. We have published a series of Technical Reports covering this subject, including TR-91 “Shielding Quality of Bal Spring® Cantled Coil Springs and Other EMI Gaskets,” TR-92 “Shielding Effectiveness of Bal Spring® Cantled Coil Springs for EMI,” and TR-93 “EMI Gasket Test Methods—Transfer Impedance vs. Radiated Shielding Effectiveness.” To obtain your copy of these reports, visit the technical library section of our website at [www.balseal.com](http://www.balseal.com).

## Spring Sizing

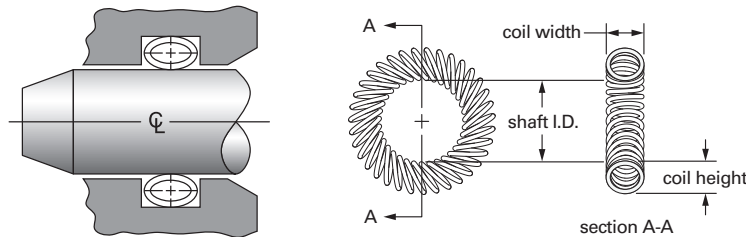

Spring Series*	Min.-Max. Coil Height (CH) in.*	Min.-Max. Coil Width (CW) in.	Min. Inside Diameter (ID) (shaft) in.
102	0.0080-0.0160	0.0090-0.0200	0.0160
101	0.0160-0.0310	0.0170-0.0400	0.0320
100	0.0310-0.0630	0.0320-0.1050	0.0620
104	0.0630-0.0940	0.0650-0.1250	0.1260
105	0.0940-0.1250	0.0970-0.1550	0.1880
106	0.1250-0.1880	0.1290-0.2700	0.2500
107	0.1880-0.2500	0.1940-0.4400	0.3760
108	0.2500-0.3750	0.2580-0.4500	0.5000
109	0.3750-0.5000	0.3870-0.6800	0.7500
1010	0.5000-0.6250	0.5150-0.7900	1.0000
1011	0.6250-0.8130	0.6440-0.9600	1.2500
1012	0.8130-1.0000	0.8380-1.0050	1.6260

**Note:**

Please give consideration to the fact that the ( $Z_T$ ) values provided throughout this catalog and other documents are the product of specific test samples, hardware, and procedures. For these reasons, the data may be subject to variations with respect to our users’ actual hardware and in-use conditions. The only verifiable method to determine the shielding performance is through actual testing of hardware under real or accurately simulated operating conditions. The information set forth herein is solely for user’s reference, and is not, in part or full, to be considered as constituting a warranty or representation of performance for which we will assume responsibility.

\*Other spring sizes available upon request.

\*\*Extremes in coil height or width require custom grooves. Contact Bal Seal Engineering for more information.

## Shielding Performance for Various Applications

The following results were compiled from transfer impedance (SAE ARP 1705) measurements taken from over 150 different configurations. Each graph presents its data in terms of a specific parameter—materials and platings, groove types, and forces (See Figures 10–12). The data is averaged for each type within the parameter groupings. Comparative performance between the different types within a graph is expressed in percentage.

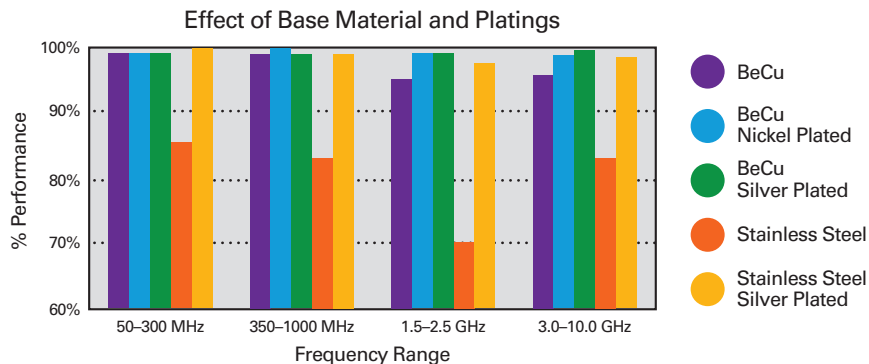

**Figure 10.** Springs made from stainless steel and copper alloy base materials were plated with nickel and silver. This graph shows their effect on transfer impedance ( $Z_T$ ) measurements.

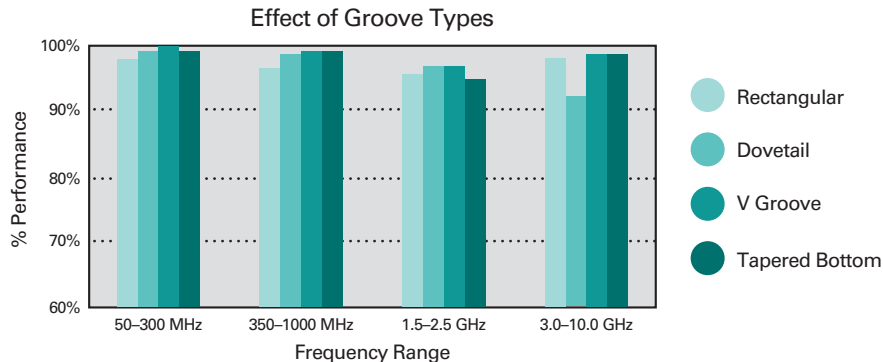

**Figure 11.** Four groove types were evaluated: rectangular, dovetail, tapered bottom, and V Groove. This graph shows their effect on transfer impedance measurements.

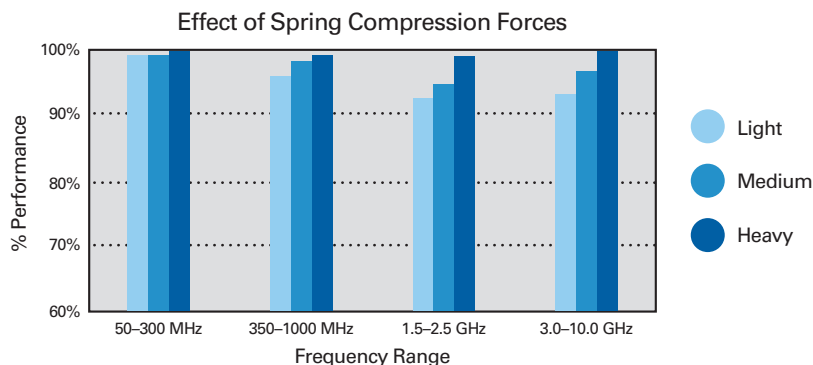

**Figure 12.** Three different spring forces per size were evaluated: light, medium, and heavy. transfer impedance performance was gained with increased force.

# Materials & Plating

## Spring Wire Materials

Copper alloy and stainless steel are the standard base materials for Bal Spring® canted coil springs for EMI shielding. These materials exhibit an excellent combination of mechanical and electrical properties and allow for the manufacture of springs of the highest performance and reliability.

Copper alloy is conductive enough to be used unplated in many applications. Stainless steel will benefit by being plated with a more conductive metal. A spring composed of stainless steel will have a higher force-per-unit compression than one of identical dimensions made from copper alloys.



Wire Material	Conductivity IACS	Resistivity $\mu\Omega\text{-cm}$	Comments
<b>BSE9 Copper Alloy</b>	17%	10	High conductivity, susceptible to oxidation
<b>BSE1 Stainless</b>	3%	72	High conductivity when plated, good corrosion resistance
<b>BSE3 Stainless</b>	2.9%	74	High conductivity when plated, excellent corrosion resistance

**Table 1.** Standard materials.

## Spring Wire Plating

Bal Spring canted coil springs are available with platings ideal for use in humid and/or corrosion-inducing environments, or any application in which higher conductivity is desired. The platings may be ordered to MIL standards or other specifications. Silver plating will generally provide the surfaces of highest conductivity. But, as with all finishes, corrosion potential and wear characteristics must be considered. We routinely use protective coatings on silver plating to provide corrosion resistance. The galvanic compatibility values in Table 2 are intended as a reference to materials that are in an environment of extreme temperature, humidity, and ionic conductors. Other materials and platings are available upon request.

Plating Material	Conductivity IACS	Resistivity $\mu\Omega\text{-cm}$	Galvanic Compatibility
Gold	74%	2.35	Silver, Titanium, Platinum
Silver	105%	1.59	Nickel, Titanium, AISI 300 Steels
Nickel	19%	7.98	Copper, Brass, Beryllium Copper, Tungsten
Tin	15%	11.0	Chromium plating, Aluminum alloys, Galvanized Steel series, Brass

**Table 2.** Conductivity values are percentages of standard copper conductivity. References: Metals Handbook, American Society for Metals, 1998. TR-85, Galvanic Compatibility for Spring Materials, Bal Seal Engineering 2002.

## Technical Support

Our team of skilled application engineers is standing by to help you tackle your toughest EMI shielding challenges. Just use the online "design request form" at [www.balseal.com](http://www.balseal.com) to provide us with some basic application data, and we'll respond with a detailed design proposal, material choices and more.





# Important Information

## Cleaning

Bal Seal Engineering products may require cleaning and/or sterilization before use, depending on the application.

## Testing

It is essential that the customer run evaluation tests to determine if the proposed, supplied, or purchased Bal Seal Engineering products are suitable for the intended purpose. Run tests under actual service conditions with an adequate safety factor.

Welded springs have an increased probability of breaking or failing at or near the weld. This probability is magnified if the spring is used in an application involving extension of the spring. In addition, temperature affects the properties of the spring (i.e., tensile strength, elongation, etc.) Failure of Bal Seal Engineering products can cause equipment failure, property damage, personal injury, or death. Equipment containing Bal Seal Engineering products must be designed to provide for any eventuality that may result from a partial or total failure of Bal Seal Engineering products.

Bal Seal Engineering products must be tested with a sufficient safety factor after installation and be subjected to a program of regular maintenance and inspection. The customer, through analysis and testing, is solely responsible for making the final selection of the products and for ensuring that all performance, safety, and other requirements of the application are met.

All information and recommendations contained herein are based on tests Bal Seal Engineering believes to be reliable, but the accuracy or completeness is not guaranteed. Any such information or recommendation is given solely for purposes of illustration and is not to be construed as a warranty that any goods will conform to such information or recommendation. No one, including Bal Seal Engineering employees, salespersons, representatives, wholesalers, or distributors is authorized to make any warranty or representation, and no customer or other user may rely on any such warranty or representation. Bal Seal Engineering reserves the right to make any changes (such as dimensional data, force, torque, materials, pressures, temperatures, surface finishes, surface speed, etc.) without notice to its products and to the contents of this document.

Nothing contained herein or in any of Bal Seal Engineering's literature constitutes a license or recommendation to use any process, or to manufacture, or to use any product in conflict with existing or future patents covering any product material or its use.

## Disclaimer of all Warranties

The implied warranties of merchantability and fitness for a particular purpose and all other implied warranties are expressly disclaimed. There are no express warranties, except those, if any, specifically enumerated in this document.

## Limitation of Liability/Remedies

The liability of Bal Seal Engineering, whether as a result of breach of any warranty, failure to provide timely delivery products, product malfunction, negligence or otherwise, shall be limited to repairing or replacing the non-conforming products or any part thereof, or, at Bal Seal Engineering's option, to the repayment to the customer all sums paid by the customer upon return to Bal Seal Engineering of the non-conforming products or part thereof. It is expressly agreed that the customer's remedy, as stated above, shall be exclusive and that under no circumstances shall Bal Seal Engineering be liable for any other damages, including direct, indirect, incidental, or consequential damages (LE-173-5 Rev. 0).

## Patents

The products described herein include those which are the subject of pending and issued patents, both foreign and domestic, including patents 5,411,348; 5,474,309; 5,545,842; 5,599,027; (LE-88G) (170-3-1) (PR#621-11).

Copyright 2024, Bal Seal Engineering LLC

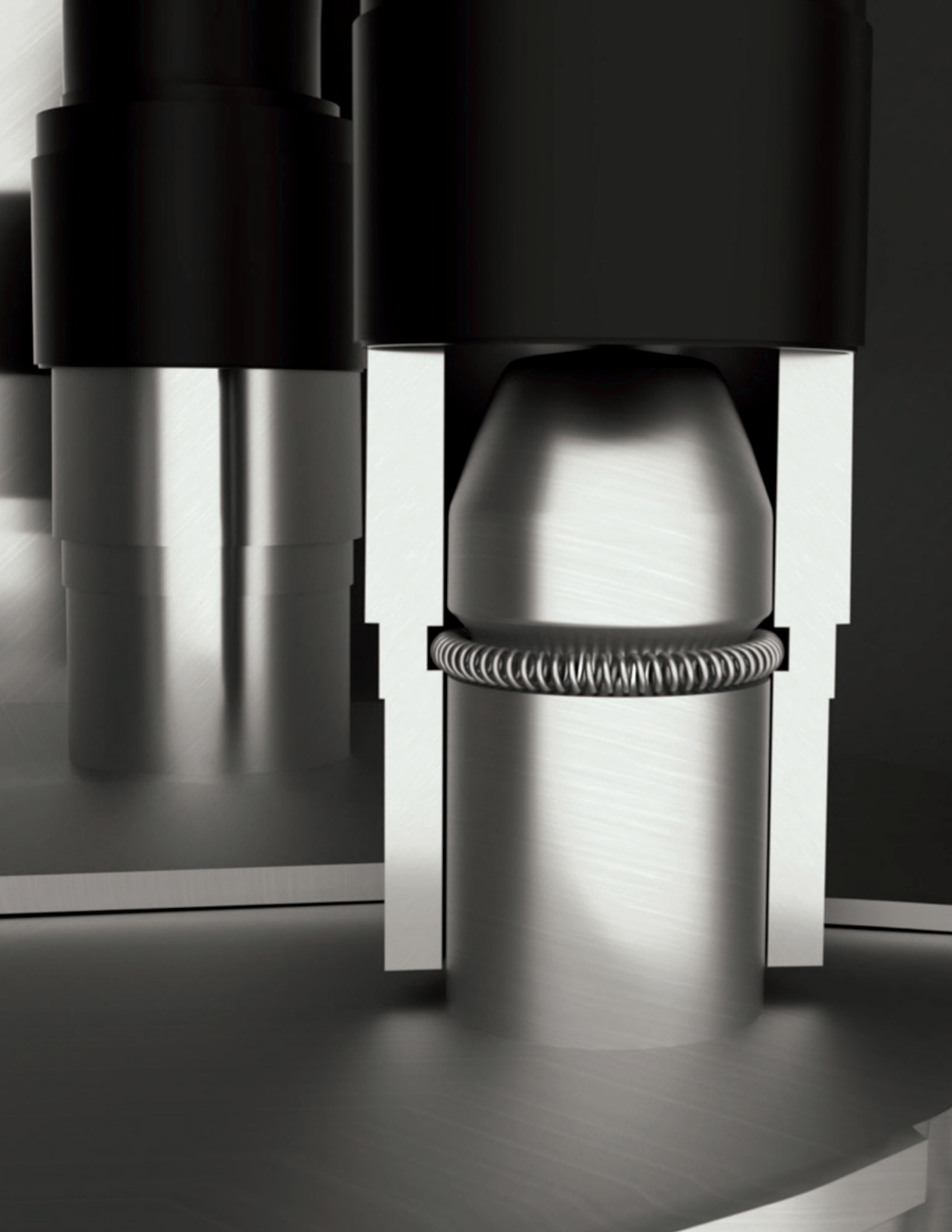

We're more than just a component maker. In early development or existing product improvement stages, we combine our proven seals, springs, and electrical contacts with engineering, material science, and precision manufacturing expertise to produce solutions that break down performance barriers.



#### **Americas\***

19650 Pauling,  
Foothill Ranch, CA 92610-2610  
Telephone +1 949 460 2100  
Fax +1 949 460 2300

#### **Europe, Middle East, Africa**

VIDA Building, 1st Floor  
Kabelweg 57  
1014 BA Amsterdam  
The Netherlands  
Telephone +31 20 638 6523  
Fax +31 20 625 6018

#### **Asia Pacific**

Suite 701, Chinachem Century Tower  
178 Gloucester Road, Wanchai, Hong Kong  
Telephone +852 2868 1860  
Fax +852 2295 6753

\*Registered manufacturing facilities in California and Colorado enable us to ensure on-time product delivery, and help you mitigate risk.

[www.balseal.com](http://www.balseal.com)



Custom components that drive tomorrow's technologies.®

